

Plain Weave Wire Mesh

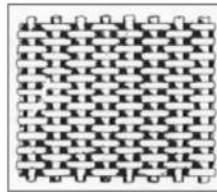

Plain Dutch Weave Wire Mesh

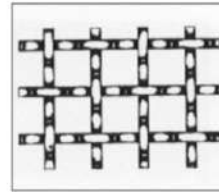

Crimped Woven Wire Mesh

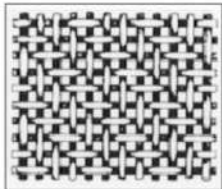

Twilled Weave Wire Mesh

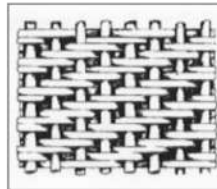

Twilled Dutch Weave Wire Mesh

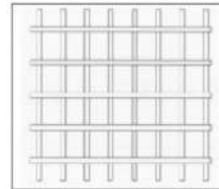

Welded Wire Mesh

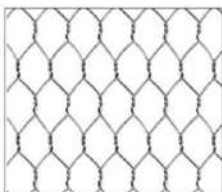

Hexagonal Wire Mesh



Expanded Metal Mesh

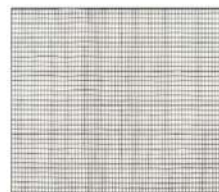

Mosquito Screens

## LAI XINFENG WIREMESH (1965) PTE LTD 賴信逢網業 (1965) 私人有限公司

Incorporated in Singapore. Established since 1965.

**Lai Xinfeng (LXF)** markets itself as the regional distributor of Wiremesh in the Asia Pacific Region.

We specialise in all kinds of Wiremesh, facade mesh and architectural mesh made from a wide range of materials.

Materials include steel, stainless steel, galvanized iron, brass, aluminium, and even synthetic fabrics such as polyvinyl, polypropylene, polyester and high density polyethylene.

**Wiremesh have many different applications such as;**

- separation plants in the air, oil and gas industry
- filtration mesh for food, edible oils and beverage
- mesh supplied for shipbuilding/repair
- steel fabricators, building and construction industry
- mesh for architectural and design purposes

Address: Block 30 Kelantan Road,  
#01-91, Singapore 200030

Email: [sales@meshlxf.com.sg](mailto:sales@meshlxf.com.sg)

Tel: (+65) 6294 1140

Fax: (+65) 6293 2425

# LAI XINFENG WIREMESH (1965) PTE LTD

## 賴信逢網業(1965)私人有限公司

Below are the products we can supply:

- HIGH/MEDIUM SECURITY PRISON/MILITARY FENCE
- DOUBLE SKIN HIGH SECURITY FENCE
- SECURITY FENCE/BOUNDARY FENCE/TEMPORARY FENCE
- HDG WELDED FENCE (ROLL TOP/BOTTOM OR FLAT TYPE PROFILE)
- HDG ANTI CLIMB FENCE/ANTI CLIMB SPIKES
- V-PRESS PROFILE SECURITY FENCE
- AIRPORT SECURITY FENCE
- SUB STATION SECURITY FENCE
- TENNIS COURT FENCE
- EXPANDED METAL SECURITY MESH
- SUS304/316/316L WELDED MESH PANELS
- GALFAN WELDED FENCE  
(DULL FINISH BUT BETTER ANTI CORROSION RESISTANCE THAN HDG COATING)
- FENCING ACCESSORIES U CLIPS/CARRIAGE BOLT/NUT/POST CAP
- STAINLESS STEEL/GALVANIZED/ALUMINIUM/PVC COATED CHAIN LINK FENCE
- STAINLESS STEEL/ALUMINIUM/PVC COATED/GALVANIZED BARBED WIRE
- STAINLESS STEEL/GALVANIZED CONCERTINA RAZOR WIRE
- STAINLESS STEEL/GALVANIZED EXPANDED MESH RAZOR WIRE
- SUS304/316 WELDED MESH (IN ROLLED FORM)
- HOT DIPPED GALVANIZED (OUTDOOR USE)/PRE GALVANIZED (IN DOOR USE)  
WELDED MESH (IN ROLLED FORM)
- HOT DIPPED GALVANIZED/STAINLESS STEEL ROOFING MESH
- STAINLESS STEEL/GALVANISED WIREMESH FOR FLOOR SCREEDING
- EXPANDED METAL MESH (MILD STEEL/HOT DIPPED GALVANIZED/ALUMINIUM/STAINLESS STEEL 304/316)
- ANTI-VERMIN/ANTI RAT MESH
- HDG/SUS 304/316L GUTTER MESH
- GREASE FILTER MESH
- WATER TANK MESH
- AIR VENT MESH
- ANTI BIRD SCREEN/BIRD SCREEN
- GARDEN MESH/PET MESH PREMIUM QUALITY  
MADE FROM 100% NON RECYCLED HDPE RESINS/UV STABILIZED
- STAINLESS STEEL 304/316L LOUVRE MESH/SUBSTATION VENT SCREEN
- MACHINE PROTECTION MESH
- GALVANIZED/BRASS/STAINLESS STEEL 304/316/316L WOVEN MESH
- GABION MESH (WELDED AND HEXAGONAL TYPE)
- ALUMINIUM/ALUMINIUM ENAMELLED/FIBERGLASS/STAINLESS STEEL 304/316/316L  
/BLACK POWDER COATED/BRASS INSECT
- SCREEN/FLY SCREEN/MOSQUITO SCREEN
- HDPE FILTER CLOTH (JAPAN) FOR CHEMICAL FILTRATION/SWIMMING POOL USE
- PP/SUS304/316 DEMISTER MESH (CRIMPED OR FLAT)
- PARTITION SCREEN MESH/VENTILATION SCREEN MESH
- ANIMAL CAGE WELDED MESH
- HOT DIPPED GALVANIZED/STAINLESS STEEL HEXAGONAL/CHICKEN COOP MESH
- SUS 304/316 BBQ MESH
- ANTI BURGLAR/ SECURITY SCREEN MESH
- STORAGE FACILITY WELDED MESH
- WOVEN VIBRATOR/SIEVING SCREEN MESH
- PLAIN WEAVE/TWILLED WEAVE/PLAIN DUTCH/TWILLED DUTCH WEAVE/CORRUGATED OR CRIMPED MESH
- SUS 304/ 316L HAND WOVEN CABLE/WIRE ROPE AVIARY/RAILING MESH
- ALUMINIUM /GALVANIZED/PVC COATED /SUS 304/316 WIRES



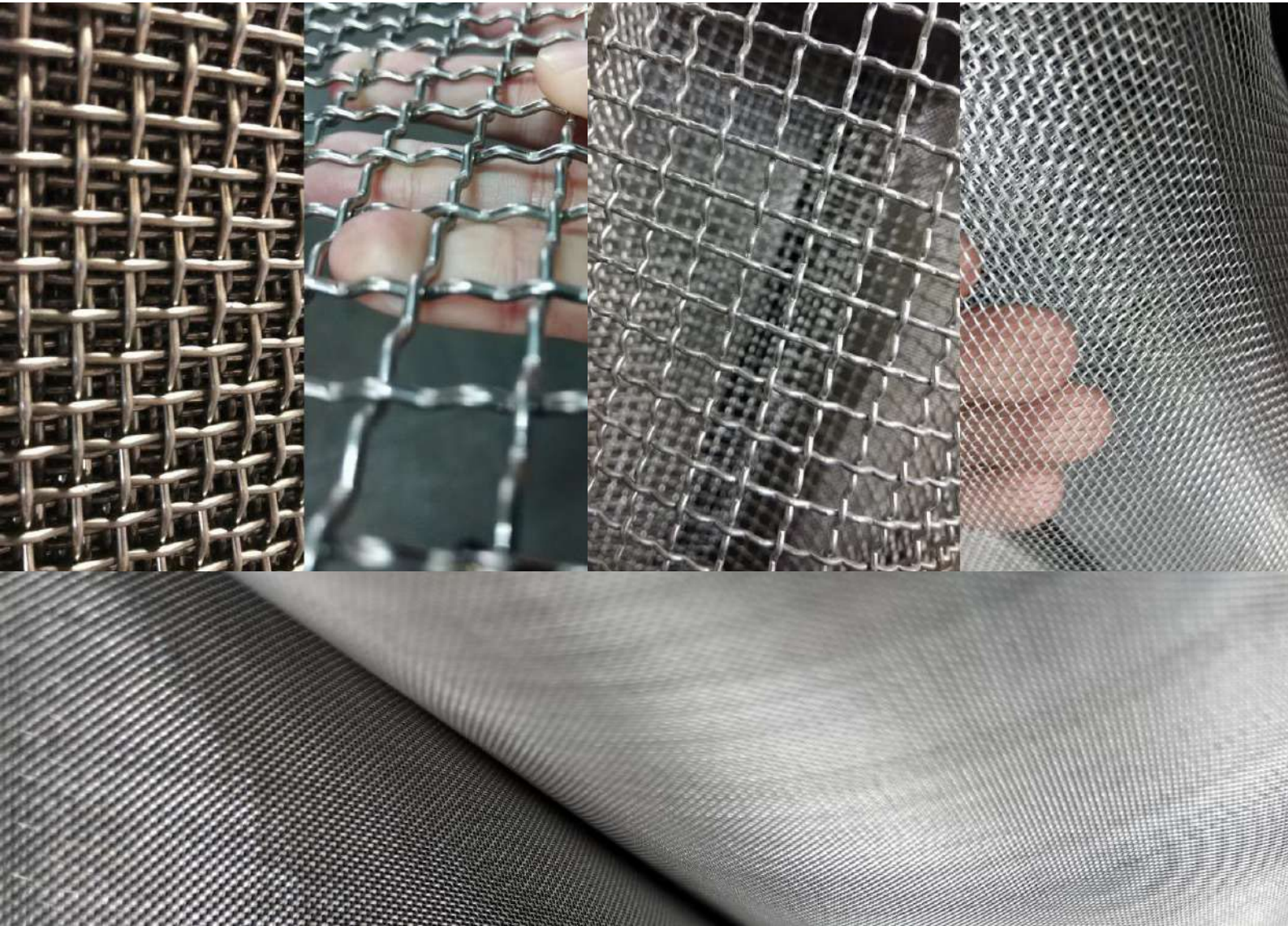

## Plain Woven Mesh / Crimped Woven Mesh

There are various weaves of wire mesh and each have their own applications.

**Plain Weave** is the simplest type of weaving method where each warp and weft wires simply “overlap” each other at right angles in equal intervals. The mesh is woven the same way cloth is woven on a loom.

Also known as wire gauze or wire cloth, woven mesh is an extremely versatile material suitable for many sieving, straining and filtering applications. It is also woven to fine limits and can be used to separate out particles of a given size.

At times, the wires are **Crimped** to provide greater stability, tightness of weave and maximum rigidity. It is commonly used when the openings are ½” or larger.

Woven wire mesh can be manufactured in an almost endless range of configurations, with a choice of wire diameter, opening size and metal materials. From thin and flexible sheets to heavier profiles, it’s specified for uses where exact mesh opening sizes are essential such as sieving, screening, safety and filtration.

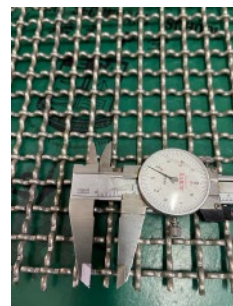
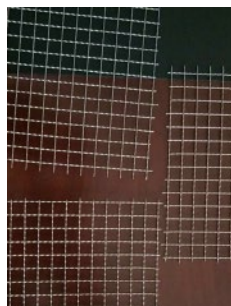

## Plain Woven Mesh

Mesh Number	Wire Diameter	Approx. Opening
2 mesh	3mm	12.5mm
3 mesh	1.2mm – 1.9mm	8.5mm
4 mesh	0.9mm – 1.6mm	6.35mm
5 mesh	0.7mm – 1.1mm	5.08mm
6 mesh	0.7mm – 1.1mm	4.23mm
7 mesh	1.1mm	3.62mm
8 mesh	0.5mm – 1.1mm	3.17mm
10 mesh	0.43mm – 1.1mm	2.54mm
12 mesh	0.45mm – 0.81mm	2.11mm
14 mesh	0.4mm – 0.7mm	1.81mm
16 mesh	0.24mm – 0.4mm	1.58mm
18 mesh	0.35mm	1.41mm
16x18 mesh	0.24mm	1.41mm x 1.58mm
20 mesh	0.24mm – 0.5mm	1.27mm
24 mesh	0.35mm	1.05mm
25 mesh	0.21mm	1.01mm
30 mesh	0.2mm – 0.35mm	0.84mm
30x40 mesh	0.18mm	0.84mm x 0.63mm
40 mesh	0.14mm – 0.3mm	0.63mm
50 mesh	0.18mm – 0.23mm	0.5mm
60 mesh	0.14mm – 0.28mm	0.42mm
80 mesh	0.12mm – 0.14mm	0.31mm
100 mesh	0.1mm – 0.11mm	0.25mm
110 mesh	0.09mm	0.23mm
120 mesh	0.08mm	0.21mm
150 mesh	0.06mm	0.16mm
180 mesh	0.05mm	0.14mm
200 mesh	0.05mm	0.12mm
300 mesh	0.04mm	0.08mm
400 mesh	0.03mm	0.06mm
500 mesh	0.025mm	0.05mm

## Crimped Woven Mesh

Approx. Opening	Wire Diameter
10mm x 10mm	1.5mm – 2mm
12.5mm x 12.5mm (1/2" x 1/2")	2mm – 3mm
20mm x 20mm (3/4" x 3/4")	3mm
25mm x 25mm (1" x 1")	3mm
38mm x 38mm (1 1/2" x 1 1/2")	3mm
8.4mm x 8.4mm (3 mesh)	1.1mm – 1.5mm
6.35mm x 6.35mm (4 mesh)	0.9mm – 1.1mm
3.17mm x 3.17mm (8 mesh)	1.1mm

### **Mesh comes in materials such as:**

- Stainless Steel 304
- Stainless Steel 304A
- Stainless Steel 316
- Stainless Steel 316L
- Black Powder Coated
- Galvanized
- Mild Steel

### **Standard Roll or Sheet Sizes are:**

- 1m x 30m
- 3ft x 30m
- 4ft x 30m
- 5ft x 30m
- 4ft x 8ft
- 4ft x 50ft

**Production tolerance: +- 5%**

**Availability subjected to prior sales**

**Products we are able to supply are not limited to what is shown in the table.**

**Please contact us for more information.**





## **Insect Screen / Fly Screen / Mosquito Netting**

Recognised throughout the world as the state of the art in precision weaving, LXF shade and mosquito screening products are also preferred by major window and door manufacturers and by consumers who purchase screening for home repairs and do-it-yourself home improvement projects. LXF's range of quality screens are available in Aluminium, Galvanised, Stainless Steel, Poly Vinyl, Fiberglass and Electro-anodised materials.

<b>Material (Color)</b>	<b>Mesh Number</b>	<b>Approx. Opening</b>	<b>Wire Diameter</b>	<b>Standard Sizes</b>
Fiberglass (Black)	18x16	1.13mm x 1.31mm	0.28mm	4ft x 30m
Fiberglass (Grey)				
Fiberglass (White)				
Fiberglass (Grey)	18x16	1.13mm x 1.31mm	0.28mm	1.6m x 30m
Fiberglass (Black)	18x30	1.13mm x 0.56mm	0.28mm	4ft x 30m
Aluminum (Black)	18x16	1.13mm x 1.31mm	0.28mm	4ft x 100ft
Aluminum (Silver)				
Polyethylene (Green)	16x16	1.31mm	0.28mm	3ft x 100ft
Polyethylene (White)				
Polyethylene (Blue)	14x16	1.57mm x 1.34mm	0.24mm	3ft x 100ft
Polyethylene (White)				

**LAI XINFENG WIREMESH (1965) PTE LTD**  
**賴信逢網業 (1965) 私人有限公司**

**Availability subjected to prior sales**  
**Please contact us for more information.**

Address: Block 30 Kelantan Road,  
 #01-91, Singapore 200030

Email: [sales@meshlxf.com.sg](mailto:sales@meshlxf.com.sg)  
 Tel: (+65) 6294 1140  
 Fax: (+65) 6293 2425

## Insect Screen / Fly Screen / Mosquito Netting (STAINLESS STEEL)

Material	Mesh Number	Approx. Opening	Wire Diameter	Standard Sizes
SS316	14x14	1.36mm	0.45mm	5ft x 30m
SS304A	14x14	1.36mm	0.45mm	1m x 30m
SS304A	14x14	1.4mm	0.4mm	1m x 30m
				4ft x 30m
SS316	14x14	1.4mm	0.4mm	4ft x 30m
SS316 Powder-coated Black Color				
SS304A	16x16	1.19mm	0.4mm	1m x 30m
				4ft x 30m
SS304A	16x16	1.12mm	0.45mm	1m x 30m
SS316	16x16	1.34mm	0.24mm	1m x 30m
				4ft x 30m
				5ft x 30m
SS304A	16x16	1.34mm	0.24mm	4ft x 30m
SS304A	18x16	1.18mm x 1.34mm	0.24mm	4ft x 30m
SS304A	18x18	1.06mm	0.35mm	1m x 30m
SS304A	20x20	1.03mm	0.24mm	1m x 30m
				4ft x 30m
				5ft x 30m
SS304A Powder-coated Black Color	20x20	1.03mm	0.24mm	4ft x 30m





## Security Window Screen / Security Door Screen (STAINLESS STEEL)

Material	Mesh Number	Approx. Opening	Wire Diameter	Standard Sizes
SS304	8x8	2.0mm	1.1mm	1m x 30m
SS304A	10x10	1.74mm	0.8mm	1m x 30m
				4ft x 30m
SS304A	10x10	1.84mm	0.7mm	1m x 30m
SS304A	10x10	1.44mm	1.1mm	1m x 6m
				1m x 12m
SS304A	12x12	1.41mm	0.7mm	5ft x 30m
SS316	12x12	1.54mm	0.58mm	5ft x 30m
SS304A	12x12	1.54mm	0.58mm	36.5" x 30m
SS304A Powder-coated Black Color	12x12	1.54mm	0.58mm	36.5" x 30m
SS304A Powder-coated Black Color	12x12	1.30mm	0.81mm	3ft x 30m
SS304	14x14	1.12mm	0.7mm	1m x 30m



**LAI XINFENG WIREMESH (1965) PTE LTD**  
**賴信逢網業 (1965) 私人有限公司**

Address: Block 30 Kelantan Road,  
 #01-91, Singapore 200030

Email: [sales@meshlxf.com.sg](mailto:sales@meshlxf.com.sg)

Tel: (+65) 6294 1140

Fax: (+65) 6293 2425

# Stainless Steel Anti-Termite Plain Woven Mesh

Material	Mesh Number	Mesh Opening	Wire Diameter	Standard Sizes
SS316	40x40	0.46mm	0.18mm	1m x 30m
SS304				
SS316	30x40	0.66mm x 0.46mm	0.18mm	1m x 30m
SS304				

Stainless Steel Woven Mesh can be an effective means of preventing subterranean termites from entering homes from below the ground. During the construction process, stainless steel woven mesh are added to help block termite entry points in the concealed area.

The plain woven mesh have tiny apertures that are too small for the termites to squeeze through. It acts as a barrier at any susceptible entry points in the home.

Production tolerance: +- 10%  
Availability subjected to prior sales  
Products we are able to supply are not limited to what is shown in the table.

Please contact us for more information.

Address: Block 30 Kelantan Road,  
#01-91, Singapore 200030

**LAI XINFENG WIREMESH (1965) PTE LTD**  
**賴信逢網業 (1965) 私人有限公司**

Email: [sales@meshlxf.com.sg](mailto:sales@meshlxf.com.sg)  
Tel: (+65) 6294 1140  
Fax: (+65) 6293 2425





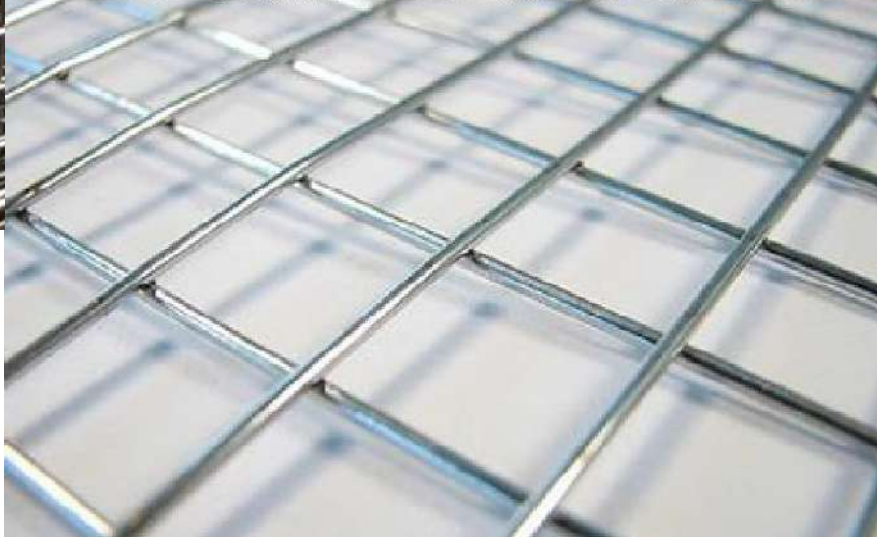
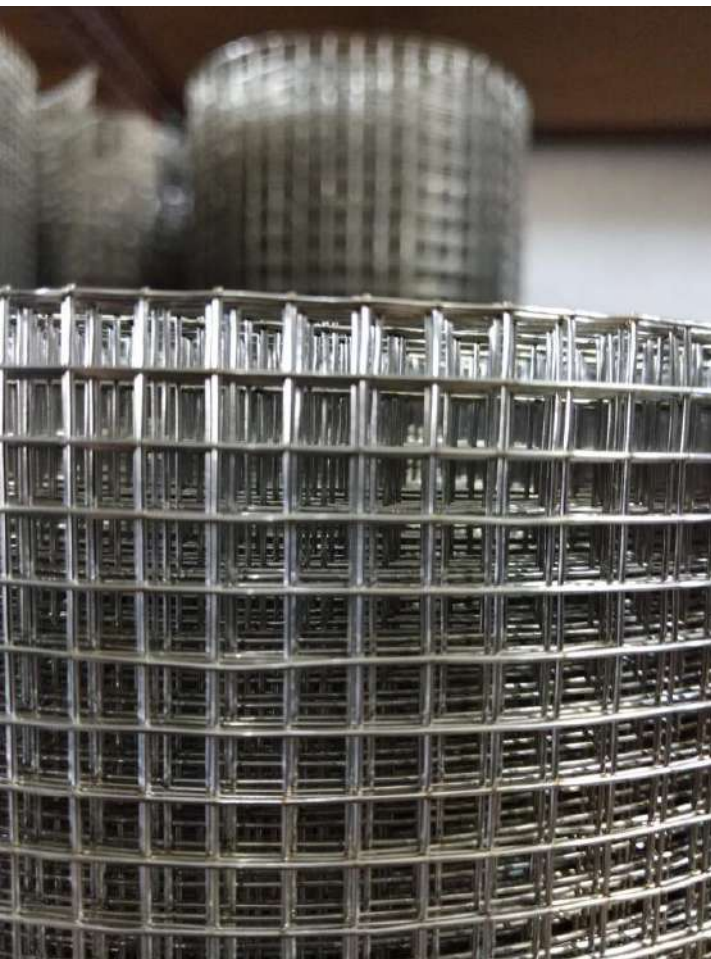

## Welded Mesh

Welded Mesh is of generally larger opening sizes compared to woven mesh, which consists of a series of parallel and perpendicular wires spaced at equal distances being welded at the intersections.

The welded mesh provides more strength and rigidity to maintain uniform squares or rectangular shapes. Applications for welded meshes include partitions, security panels, fences, cages, gabions and even as a support mesh for filtrations.

---

## Welding Procedure

Once the wires are drawn down to the desired size or thickness, it is strung through a row of automatic feeders that is set to the desired grid. The feeder pushes the long parallel strands of wire through the welder while another feeder drops perpendicular sections of wire down from the top on to the parallel wires.

The machine then welds multiple rows of wires together at the intersection simultaneously by using a row of electrical resistance weld heads which then fuses the joints. The mesh is then pushed or pulled ahead so that the next row can be welded.

This process continues, joining each row of wires together until it has reached its desired dimensions. It is then cut by a shear resulting in a flat and rigid sheet of welded wire mesh.

## Welded Mesh

Mesh Opening		Wire Diameter
Inch	Metric	
1/4"	6.35mm	0.7mm – 1.2mm
3/8"	9.5mm	0.9mm – 1.2mm
1/2"	12.5mm	0.55mm – 2mm
5/8"	15.8mm	1.5mm
3/4"	19.05mm	1.5mm – 3mm
1"	25mm	1mm – 3.5mm
1 1/2"	38.1mm	3mm
2"	50mm	2mm – 6mm
3"	75mm	3mm – 5mm
4"	100mm	4mm – 6mm
5"	125mm	5mm
1/2" x 1"	12.5mm x 25mm	1.5mm – 2.5mm
1/2" x 3"	12.5mm x 75mm	3mm – 4mm
1" x 2"	25mm x 50mm	2mm – 5mm
1" x 3"	25mm x 75mm	3mm – 4mm
2" x 4"	50mm x 100mm	5mm
2" x 6"	50mm x 150mm	5mm
6"	150mm	6mm

### Mesh comes in materials such as;

- Stainless Steel 304
- Stainless Steel 304A
- Stainless Steel 316
- Stainless Steel 316L
- Black Powder Coated
- Galfan
- Galvanized
- Hot-dipped Galvanized
- Mild Steel

### Standard Roll or Sheet Sizes;

- 1m x 30m
- 3ft x 30m
- 4ft x 30m
- 5ft x 30m
- 1.2m x 2.4m
- 1.5m x 2.4m
- 1.8m x 2.4m
- 2.1m x 2.4m
- 2.4m x 2.4m
- 3ft x 70ft
- 3ft x 90ft
- 4ft x 38ft

**Production tolerance: +- 5%**

**Availability subjected to prior sales**

**Products we are able to supply are not limited to what is shown in the table.**

**Please contact us for more information.**



**GALVANIZED / STAINLESS STEEL / PVC COATED**  
**Bird Screen Netting / Anti Bird Mesh / Louvre Mesh**

Mesh Opening		Wire Diameter	Standard Sizes
Inch	Metric		
1/4" x 1/4"	5.65mm	0.7mm	1m x 30m, 4ft x 30m
	0.50mm	0.8mm	4ft x 30m
3/8" x 3/8"	9.0mm	0.9mm	1mx 30m, 5ft x 30m
	7.3mm	1.2mm	4ft x 30m
1/2" x 1/2"	12.5mm	0.7mm	4ft x 30m
1/2" x 1/2"	12.0mm	1mm	1m x 30m, 4ft x 30m
		1.1mm	4ft x 30m
		1.2mm	4ft x 30m
		1.5mm	3ft, 4ft, 1m x 30m
3/4" x 3/4"	20mm	1.5mm	4ft x 30m
		2.0mm	
1" x 1"	25mm	1.0mm	4ft x 30m
		1.2mm	
1" x 1"	24mm	1.5mm	4ft x 30m
1" x 1"	23.5mm	2.0mm	3ft, 4ft, 1m x 30m

Production tolerance: +- 10%

Availability subjected to prior sales

Products we are able to supply are not limited to what is shown in the table.

Products listed above which are welded meshes are commonly used as bird screens / bird mesh / louvre.

Difference in sizes are based on project requirements.

Please contact us for more information.



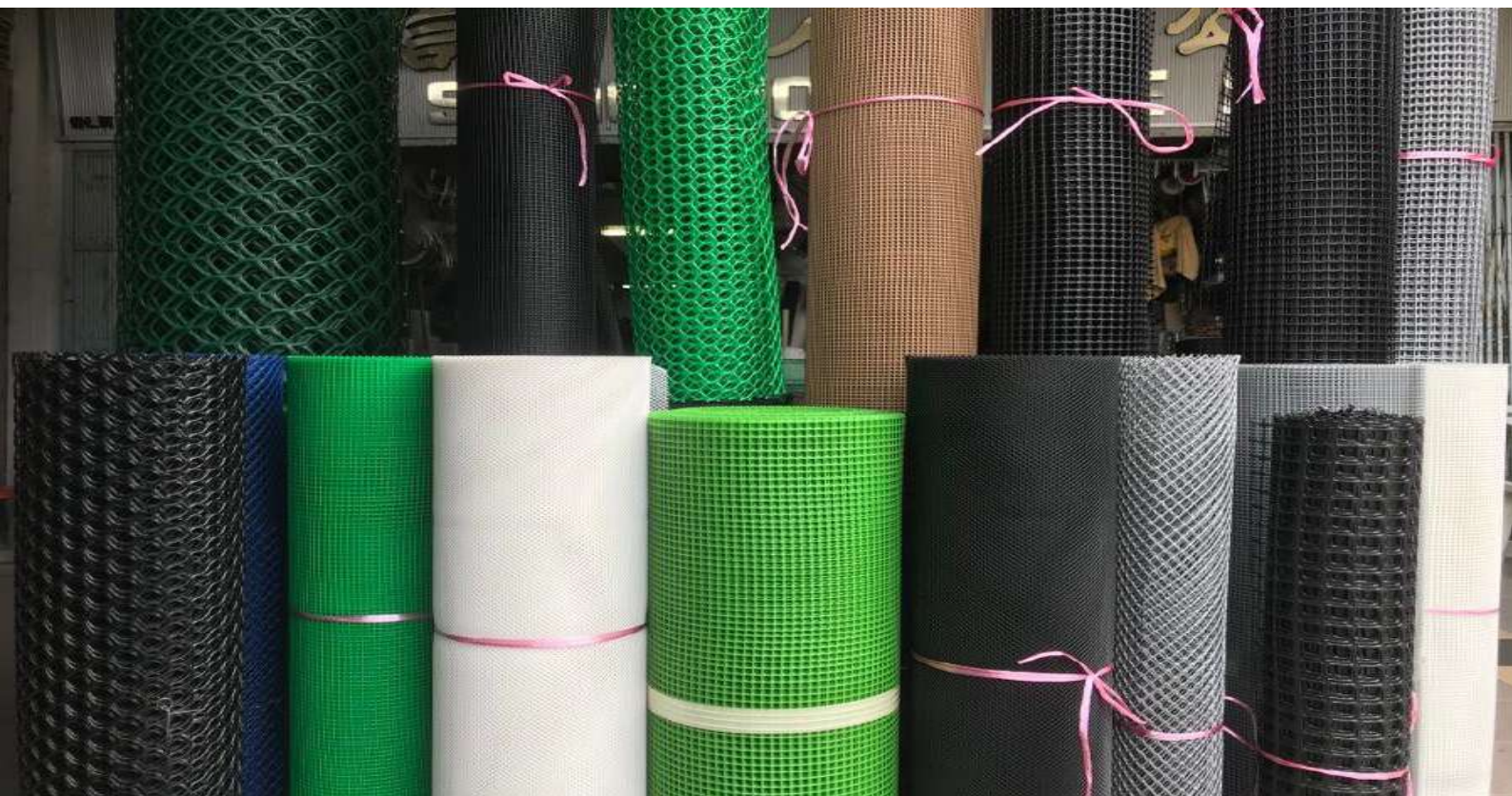

**PLASTIC (HDPE / High-density Polyethylene)**  
**Bird Screen Net / Anti Bird Mesh / Pet Mesh / Garden Mesh**

Opening	Roll Size	Color
2mm	1m x 25m	Grey
4mm	1m x 25m	Black
	1.25m x 25m	White
6mm	1m x 25m	Pink
		Black
		White
		Brown
		Green
8mm	2m x 25m	Grey
8.5mm	2m x 25m	Black
10mm	1m x 25m	Black
	2m x 25m	
11mm	1m x 25m	Black
		Brown
12mm(Hex)	1m x 25m	Grey
15mm	1m x 25m	Grey
		Black
		Green
27mm	1m x 25m	Black
		Green
	2m x 25m	Black
		Green
2"	1.8m x 25m	Black
		Green

Opening	Roll Size	Color
3mm	3ft x 30m	Black
5mm		
7mm		
9mm		
12mm		
17mm		
25mm		
50mm		

**Availability subjected to prior sales**  
**Please contact us for more information.**

**LAI XINFENG WIREMESH (1965) PTE LTD**  
**賴信逢網業(1965)私人有限公司**

Address: Block 30 Kelantan Road,  
 #01-91, Singapore 200030

Email: [sales@meshxf.com.sg](mailto:sales@meshxf.com.sg)  
 Tel: (+65) 6294 1140  
 Fax: (+65) 6293 2425



**Welded Mesh Fencing**

FA Series					
Model	Panel Size		Mesh Spacing (mm)		Wire
	Height(mm)	Width(mm)	Vertical	Horizontal	Diameter
FA900	900	2400	50mm	150mm	± 5mm
FA1200	1200				
FA1500	1500				
FA1800	1800				
FA2100	2100				
FA2400	2400				

Standard Model comes in Roll Top & Bottom OR Flat Panel  
 Other sizes available upon request  
 All sizes are subjected to manufacturing tolerance





# Welded Mesh Security Fencing

LX2575 Series					
Model	Panel Size		Mesh Spacing (mm)		Wire
	Height(mm)	Width(mm)	Vertical	Horizontal	Diameter
LX-900	900	2400	25mm	75mm	± 4mm
LX-1200	1200				
LX-1500	1500				
LX-1800	1800				
LX-2100	2100				
LX-2400	2400				

Standard Model comes in Roll Top & Bottom OR Flat Panel  
 Other sizes available upon request  
 All sizes are subjected to manufacturing tolerance





# Anti-Climb Fencing

Anti-Climb Series					
Model	Panel Size		Mesh Spacing (mm)		Wire
	Height(mm)	Width(mm)	Vertical	Horizontal	Diameter
A-900	900	2400	75mm	12.5mm	± 4mm
A-1200	1200				
A-1500	1500				
A-1800	1800				
A-2100	2100				
A-2400	2400				

Standard Model comes in Flat Panel  
 Other sizes available upon request  
 All sizes are subjected to manufacturing tolerance



---

## Anti-Climb Fencing 防爬網



REF.NO	MATERIAL	NOMINAL SIZE OF MESH SWM x LWM (mm) (mm)	THICKNESS (mm)	STRAND WIDTH (mm)	*STANDARD SHEET SIZE SWM x LWM (mm) (mm)
J3030	Steel	12.5 x 75	3.0	3.0	2440 x 1220

\*Note: Other sheet sizes available upon request



---

RAZOR BARBED WIRE

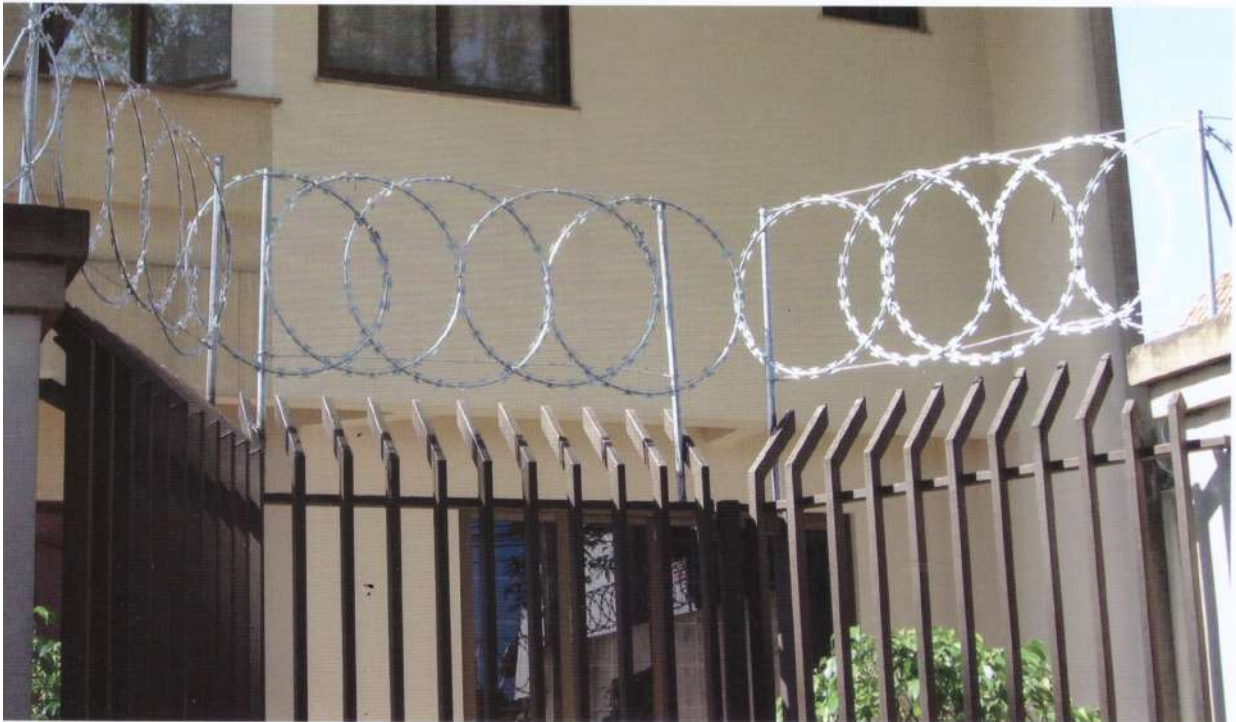
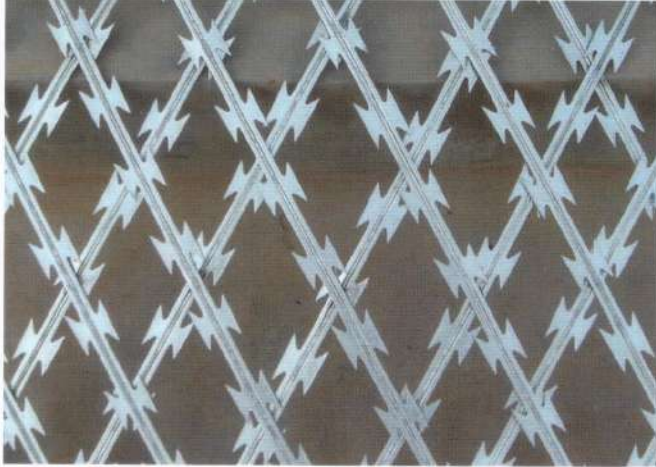



Let us first consider a mesh with conventional diamond-shaped apertures. In the expansion process the sheet metal blank is transformed by a continuous shear-and-press action into a lattice-work of undulating strands.

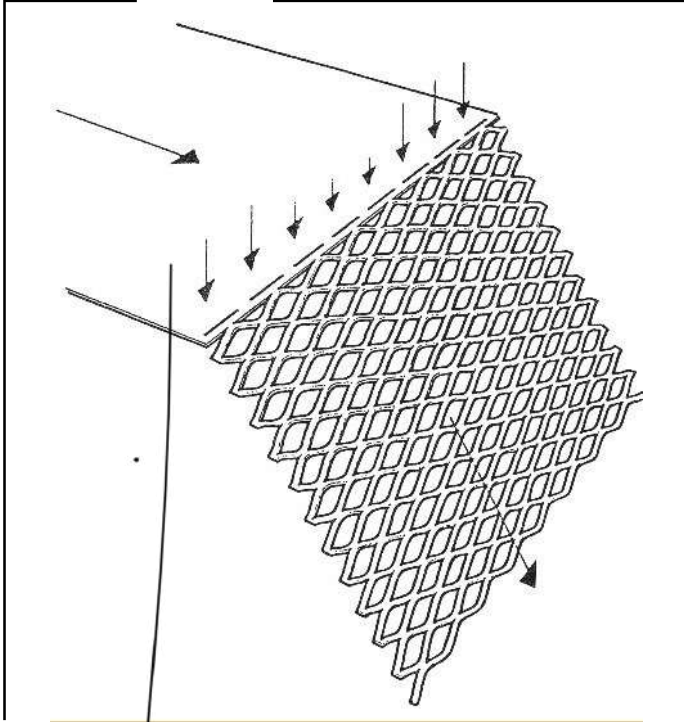

The width and the length of the strands are set at an angle to the plane of the sheet of mesh.

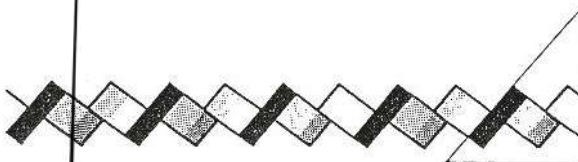

Width of strand at an angle to plane

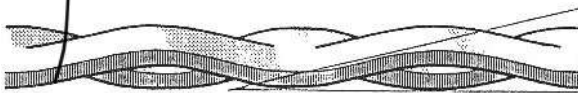

Length of strand at an angle to plane

## Specification of mesh opening

The Long Way (LWM) of the mesh opening is uniform, and the Short Way (SWM) is approximate only and is subject to variation depending on the strand width and material thickness. However, it may not generally alter the overall mesh type during manufacture.

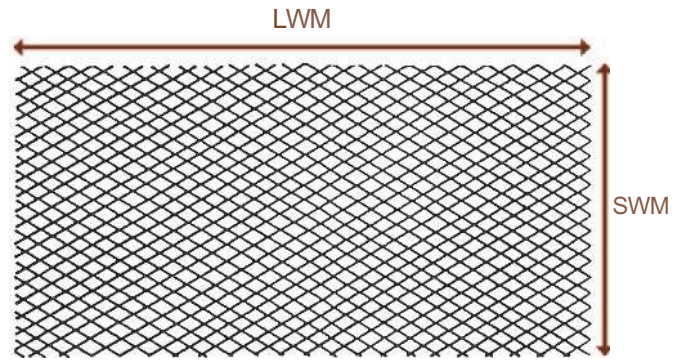

This sheet is 8'0" (2.44m) LWM x 4'0" (1.22m) SWM

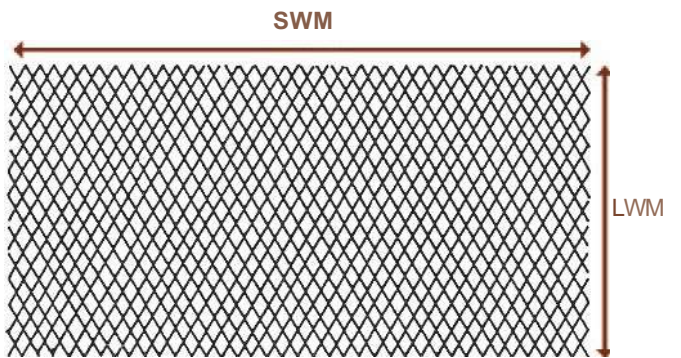

This sheet is 4'0" (1.22m) LWM x 8'0" (2.44m) SWM

## Available Material

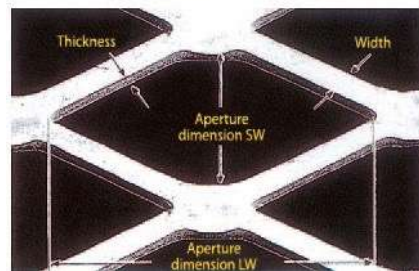
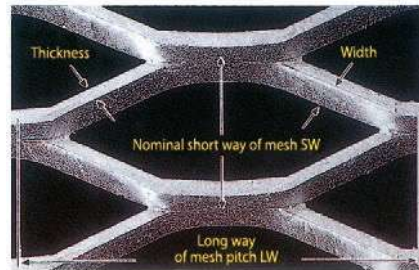

### MILD STEEL

Made from low carbon steel conforming to JIS G3131/SPHC. For non-corrosion, it can be hot dipped galvanised to BS EN ISO 1461 or powder coated.

### ALUMINIUM

Commercial Grade AA 1100 (mill finish). Other Grades of aluminium ore also possible upon request.

### STAINLESS STEEL

Usually produced from Grade SS304 and SS316.



# METAL SIZE



SWM x LWM 10 x 21



SWM x LWM 9 x 29



SWM x LWM 16 x 38

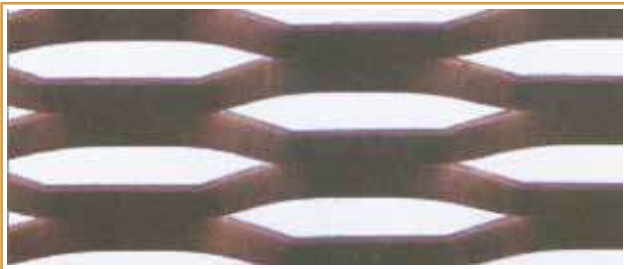

SWM x LWM 16 x 76



SWM x LWM 22 x 57

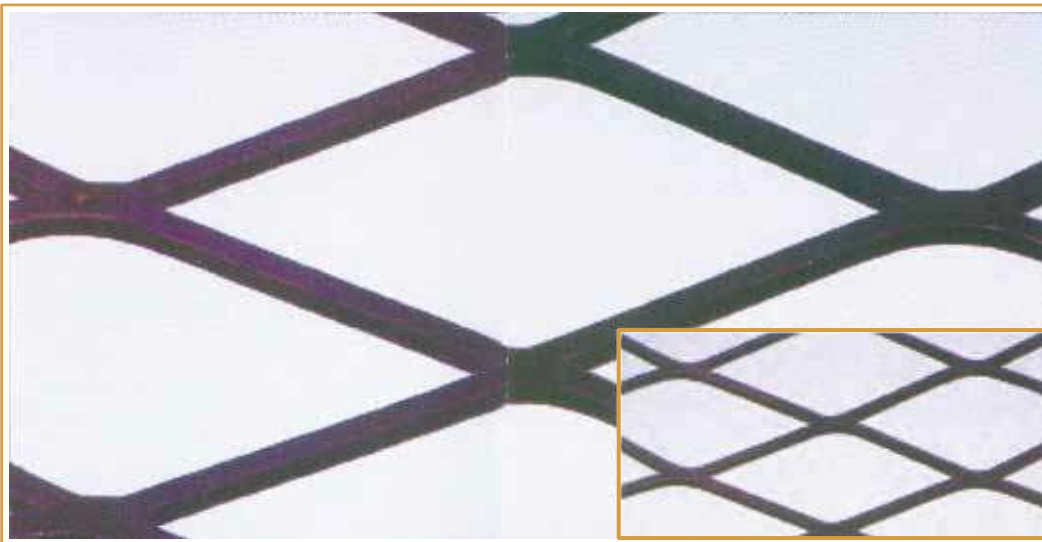

SWM x LWM 42 x 115

Detail shown at 33% actual size



SWM x LWM 95 x 200

Detail shown at 25% actual size

## METAL SIZE

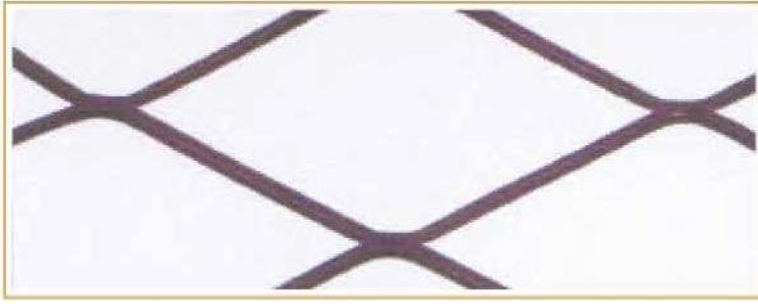

SWM x LWM 35 x 76

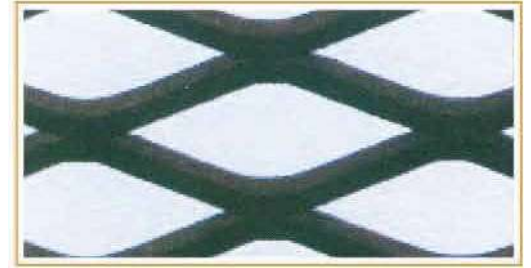

SWM x LWM 30 x 75

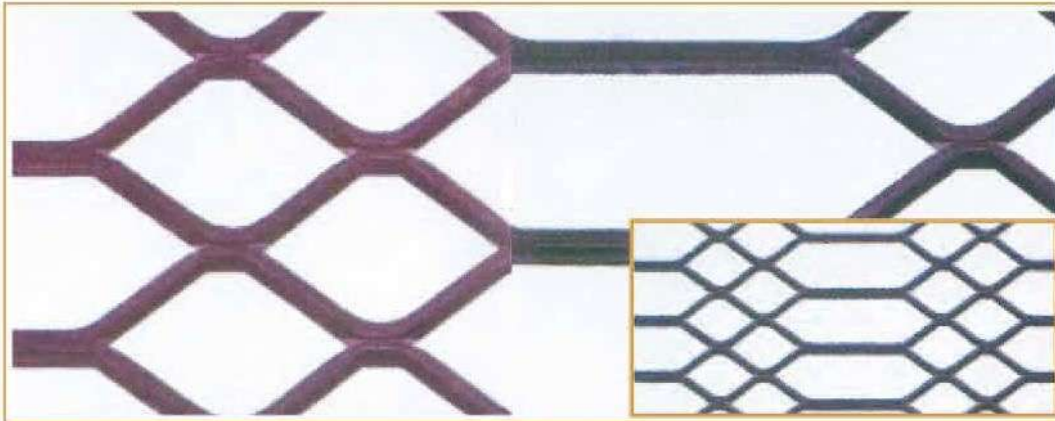

SWM x LWM 25 x 40/81

Detail shown at 25% actual size

## Product Benefits

- Because there are no welds or joints, it operates as a structural member that distributes loads evenly over a wider area.
- Lighter in weight yet stronger than steel sheet, thus economical applications for walkway platform, security fencing, machine guard, racing, etc.
- The open mesh design allows passage of light, air and sound; used for screenmesh, ventilation and security screen in many industrial buildings.
- The anti-skid surface provides safety and grip suitable for staircases, rugged maintenance floor, gratings and catwalks for factories, shipyards and oil refineries.
- Anti-corrosive when hot-dipped galvanized or powder-coated.



## Sheet Sizes & Tolerance

Expanded metal comes in standard sheet size of 2440mm(SWM) x 1220mm(LWM), other sheet sizes are available upon request. Some light meshes are supplied in roll for easy handling and storage. All sheet and roll sizes are subject to tolerance.



# SPECIFICATIONS

Type	Ref. No	Material	Nominal Size Of Mesh		Thickness* ( $\pm 10\%$ ) (mm)	Strand Width ( $\pm 10\%$ ) (mm)	Weight ( $\pm 10\%$ ) kg/m <sup>2</sup>	Standard Sheet Size SWMxLWM (mm)
			SWM (mm)	LWM (mm)				
Light Mesh	LM 0515 (GI)	Steel	10	21	0.5	1.5	1.24	2440 x 1220
	LM 0715 (GI)	Steel	10	21	0.7	1.5	1.75	2440 x 1220
	LM 0915 (GI)	Steel	10	21	0.9	1.5	2.25	2440 x 1220
	LM 1015 (GI)	Steel	9	29	1.0	1.5	2.70	2440 x 1220
	LM 1515	Steel	9	29	1.5	1.5	4.03	2440 x 1220
	LM 2015	Steel	9	29	2.0	1.5	5.37	2440 x 1220
	LM 1520	Steel	16	38	1.5	2.0	3.0	2440 x 1220
	LM 1528	Steel	22	57	1.5	2.8	3.02	2440 x 1220
	LM 2028	Steel	22	57	2.0	2.8	4.03	2440 x 1220
	LM 2030	Steel	35	76	2.0	3.0	3.02	2440 x 1220
Security & Decorative Mesh	SM 3030	Steel	22	57	3.0	3.0	6.49	2-440 x 1220
	SM 3035	Steel	22	57	3.0	3.5	7.3	2440 x 1220
	SM 30045	Steel	22	57	3.0	4.5	9.75	2440 x 1220
	SM4545	Steel	22	57	4.5	4.5	15	<b>2-440 x 1220</b>
	SM 30030	Steel	35	76	3.0	3.0	4.03	<b>2440 x 1220</b>
	SM 3045	Steel	35	76	3.0	4.5	6.05	<b>2440 x 1220</b>
	SM 45050	Steel	35	76	4.5	5.0	10.48	<b>2440 x 1220</b>
	SM 45060	Steel	35	76	4.5	6.0	72.43	<b>2440 x 7220</b>
	SM 6060	Steel	35	76	6.0	6.0	76.58	<b>2440 x 7220</b>
	SM 3545	Steel	42	115	3.0	4.5	5.37	<b>24-40 x 1220</b>
	SM 3060	Steel	42	115	3.0	6.0	7.05	<b>2-440 x 1220</b>
	SM 4560	Steel	42	115	4.5	6.0	70.41	<b>2440 x 1220</b>
	SM 3050	Steel	50	150	3.0	5.0	4.71	<b>2440 x 1220</b>
	SM 5050	Steel	75	150	5.0	5.0	5.3	<b>2440 x 1220</b>
	SM 3075	Steel	95	200	3.0	7.5	3.8	<b>2440 x 1220</b>
DM 3032	Steel	25	40/81	3.0	3.2	6.05	<b>2440 x 1220</b>	
Walkway Mesh	WM 50080	Steel	45	135	5.0	<b>8.0</b>	14.11	<b>2440 x 1220</b>
	WM 50110	Steel	45	135	5.0	11.0	19.48	<b>2440 x 1220</b>
	WM 30080	Steel	30	75	3.0	8.0	12.55	<b>2440 x 1220</b>
	WM 50075	Steel	30	75	5.0	7.5	23.5	<b>2440 x 1220</b>
	WM 50105	Steel	30	75	5.0	10.5	27.55	<b>2-440 x 1220</b>
Louvre Mesh	LOM 1563	Alum	16	76	1.5	6.3	3.4	<b>2440 x 1220</b>
	LOM 2045	Alum	12	65	2	4.5	4.1	<b>2440 x 1220</b>
	LOM 2050	Alum	13.5	45	2	5.0	4.2	<b>2440 x 1220</b>
Expanded Metal to Japan Standard								
	XG11	Steel	34	135.4	4.5	7.0	14.5	<b>2440 x 1220</b>
	XG12	Steel	<b>34</b>	135.4	6.0	7.0	<b>19.4</b>	2440 x 1220
	XG13	Steel	34	135.4	6.0	9.0	24.9	2-440 x 1220
	XG1-4	Steel	34	135.4	8.0	9.0	33.2	2-440 x 1220
	XG21	Steel	36	107.6	4.5	7.0	13.7	2440 x 1220
	XG22	Steel	36	107.6	6.0	7.0	18.3	2440 x 1220
	XG23	Steel	36	107.6	6.0	9.0	23.6	24-40 x 1220
	XG24	Steel	36	107.6	8.0	9.0	31.4	2-4-40 x 1220

\* Thickness up to 9.0mm (to a maximum of 1525mm LWM Direction)

## General Conditions

1. Standard weight tolerance, subject to  $\pm 10\%$ .
2. Nominal sheet size-shortway direction, subject to  $\pm 50\text{mm}$ .  
Nominal sheet size-longway direction, subject to  $\pm 10\text{mm}$ .
3. Also available in material such as Aluminium and Stainless Steel.
4. Specific sheet sizes also available upon request.
5. Short *WCJY* mesh and strand width may vary  $\pm 10\%$  due to manufacturing constraints. Should you need exact opening, you must discuss with our sales staff prior to ordering.

# LOADING TABLE FOR WALKWAY MESH

## SPECIFICATIONS AND LOAD/ SPAN TABLES

CAT.No.	LOAD CONDITION	LOADING CRITERIA	SIMPLE SPAN-mm				DOUBLE SPAN-mm				TRIFLE SPAN-mm						
			600	750	900	1200	300	380	450	600	200	250	300	400			
W 00	Uniform Load (KN/m <sup>2</sup> )	LOAD CAPACITY	4.9	3.1	2.25	1.22	120	12.6	8.9	5.2	1143.85	30.3	21.4	12.14			
		DEFLECTION SPAN/240 LOAD SPAN/360	9.9	5.1	3.0	1.2			19.4	8.4				26.3			
WM50110	Point Load (KN)	LOAD CAPACITY	1.0	0.85	0.74	0.53	2.5	1.96	1.68	1.27	4	3.17	2.68	2.00			
		DEFLECTION SPAN/180 LOAD SPAN/240	0.99	0.63	0.44	0.25	4.01	2.56	1.82	1.02		5.41	3.80	2.18			
WM50110	Uniform Load (KN/m <sup>2</sup> )	LOAD CAPACITY	6.43	4.2	2.9	1.7	126.73	16.6	11.9	6.7	1156	40.0	28.2	16			
		DEFLECTION SPAN/240 LOAD SPAN/360		9.4	5.5	2.2				15.3				73.1			
WM50075	Point Load (KN)	LOAD CAPACITY	0.44	0.13	0.96	0.72	3.23	2.58	2.18	1.65	4.98	4.17	3.49	2.67			
		DEFLECTION SPAN/180 LOAD SPAN/240	0.82	0.18	0.82	0.47		4.76	3.38	2.58		7.07		5.38			
WM50075	Uniform Load (KN/m <sup>2</sup> )	LOAD CAPACITY	5.8	3.7	2.6	1.5	23.4	14.9	10.5	6.0	150.4	35.9	24.9	14.3			
		DEFLECTION SPAN/240 LOAD SPAN/360	11.3	5.9	3.4	1.5			20.2	9.7				30.3			
WM50105	Point Load (KN)	LOAD CAPACITY	1.3	1.01	0.84	0.63	2.9	2.31	1.93	1.5	4.50	3.7-4	3.12	2.38			
		DEFLECTION SPAN/180 LOAD SPAN/240	1.14	0.73	0.52	0.29	6.19	3.96	2.76	1.60		6.32	4.43	3.38			
WM50105	Uniform Load (KN/m <sup>2</sup> )	LOAD CAPACITY	8.2	5.9	3.65	2.0	133.2	21.1	15.8	8.5	69.3	51.1	35.4	20.1			
		DEFLECTION SPAN/240 LOAD SPAN/360	18.3	9.4	5.5	2.4			35.7	15.5				49.2			
W 0080/E	Point Load (KN)	LOAD CAPACITY	1.8	1.43	1.20	0.90	4.12	3.29	2.76	2.08	6.28	5.29	4.49	3.38			
		DEFLECTION SPAN/180 LOAD SPAN/240	1.84	1.19	0.83	0.46		6.40	4.51	2.58		10.14	7.07	5.34			
W 0080/E	Uniform Load (KN/m <sup>2</sup> )	SPAN-mm	200	300	400	500	600	200	300	400	500	600	200	300	400	500	600
		LOAD CAPACITY	14.00	4.59	1.54	0.60	0.29	14.00	6.22	3.48	1.44	0.70	16.41	7.29	2.88	1.19	0.58

## SPECIFICATIONS AND LOAD/ SPAN TABLES

CAT.No.	LOAD CONDITION	LOADING CRITERIA	SIMPLE SPAN-mm				DOUBLE SPAN-mm				TRIFLE SPAN-mm			
			600	750	900	1200	300	380	450	600	200	250	300	400
WM50080/A	Uniform Load (KN/m <sup>2</sup> )	LOAD CAPACITY	4.5	3.0	2.0	1.1	18.4	11.7	8.5	4.7	40.2	28.4	19.8	11.4
		DEFLECTION SPAN/240 LOAD SPAN/360	3.8	2.0	1.1	0.5	37.3	18.9	11.1	4.8	64.3	40.8	35.6	15.4
WM50110/A	Point Load (KN)	LOAD CAPACITY	1.00	0.85	0.74	0.53	2.5	1.95	1.68	1.27	3.65	2.97	2.48	1.87
		DEFLECTION SPAN/180 LOAD SPAN/240	0.73	0.48	0.33	0.19	4.01	2.56	1.82	1.02	3.03	2.08	1.45	0.86
W-75/A	Uniform Load (KN/m <sup>2</sup> )	LOAD CAPACITY	5.4	3.6	2.5	1.4	22.3	16.6	11.9	6.7	49.1	34.4	24.1	13.9
		DEFLECTION SPAN/240 LOAD SPAN/360	6.4	3.3	1.9	0.8	41.7	21.1	11.1	5.4			40.1	17.4
WM50105/A	Point Load (KN)	LOAD CAPACITY	1.21	0.97	0.81	0.60	2.79	2.21	1.87	1.49	4.38	3.60	3.00	2.29
		DEFLECTION SPAN/180 LOAD SPAN/240	0.64	0.41	0.21	0.16	3.49	2.21	1.56	0.81	6.34	4.69	3.27	1.89
WM50105/A	Uniform Load (KN/m <sup>2</sup> )	LOAD CAPACITY	6.5	4.4	3.0	1.7	27.5	17.3	12.3	7.0	58.1	42.3	29.6	17.0
		DEFLECTION SPAN/240 LOAD SPAN/360	6.6	3.5	2.0	0.9	43.5	22.1	13.0	5.6	108.0	72.2	42.1	17.9
WM50105/A	Point Load (KN)	LOAD CAPACITY	1.5	1.19	1.00	0.74	3.41	2.71	2.29	1.72	5.31	4.40	3.61	2.78
		DEFLECTION SPAN/180 LOAD SPAN/240	0.67	0.44	0.30	0.17	3.6-8	2.31	1.63	0.92	6.60	4.91	3.4	1.98

### Assumption

The selection guide assumes meshing in the direction of long way mesh (LWM) having a minimum of every fourth strand welded on support and minimum 25mm end bearing.

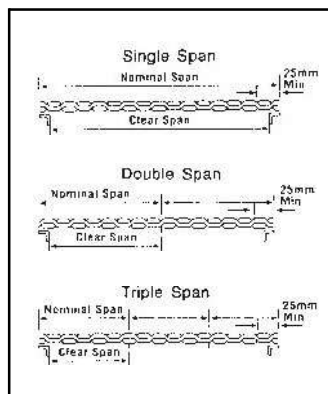

### NOTE:

1. Load capacities given in the table are heaviest loads that will cause no permanent deformation with safety factor of 1.4 times. If some permanent deformation is allowed, loads can be increased by 40%.
2. The load table is applicable base on spanning in LWM direction a spot-weld at every 4 strand on support and minimum 25mm landing on both ends.
3. Spanning recommended based on assumption that deflection is not greater than span /200.
4. Spanning stated in table are nominal. Clear spans are obtained by deducting 25mm landing on both ends.



# EXPANDED FACADE MESH

Aluminium Expanded Metal Facade Mesh can be custom make to provide a unique appealing architectural look for commercial & residential buildings.

## ALUMINIUM FACADE MESH: SPECIFICATION

Ref. No	Material	Nominal Size Of Mesh		Thickness (±10%) (mm)	Strand Width (± 10%) (mm)	Weight (±10%) kg/m <sup>2</sup>	Standard Sheet Size SWM x LWM (mm)
		SWM (mm)	LWM (mm)				
SM15016A	Aluminium	42	115	1.5	16	3.1	2440 x 1220
SM20016A	Aluminium	42	115	2.0	16	4.2	2440 x 1220
SM20015A	Aluminium	45	135	2.0	15	3.9	244.Qx 1220
SM30016A	Aluminium	48	135	3.0	16	5.5	2440 x 1220
SM20030A	Aluminium	70	150	2.0	30	4.7	2440 x 1220
SM30030A	Aluminium	70	150	3.0	30	7	2440 x 1220

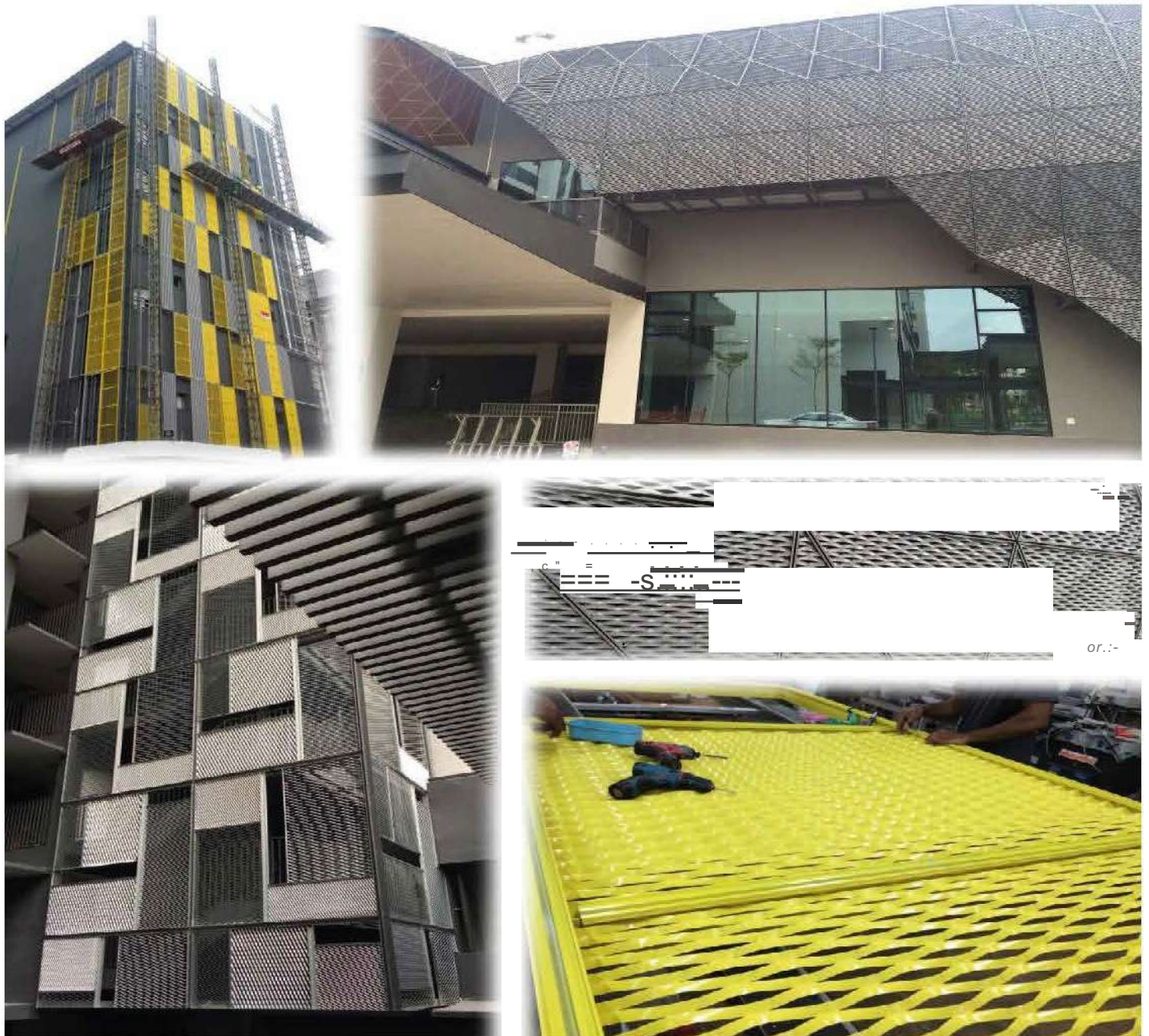



# APPLICATION

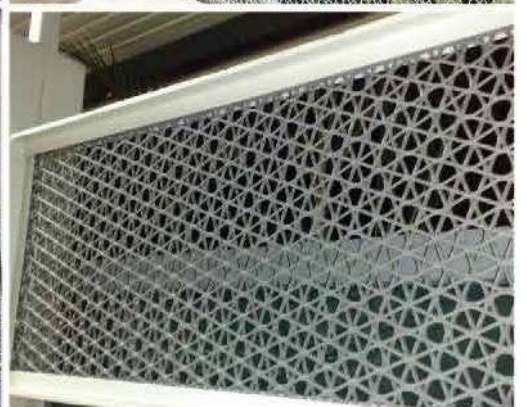
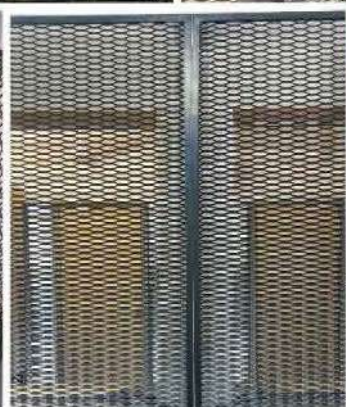



# RAZOR BARBED MESH( EXPANDED MESH TYPE) ATM

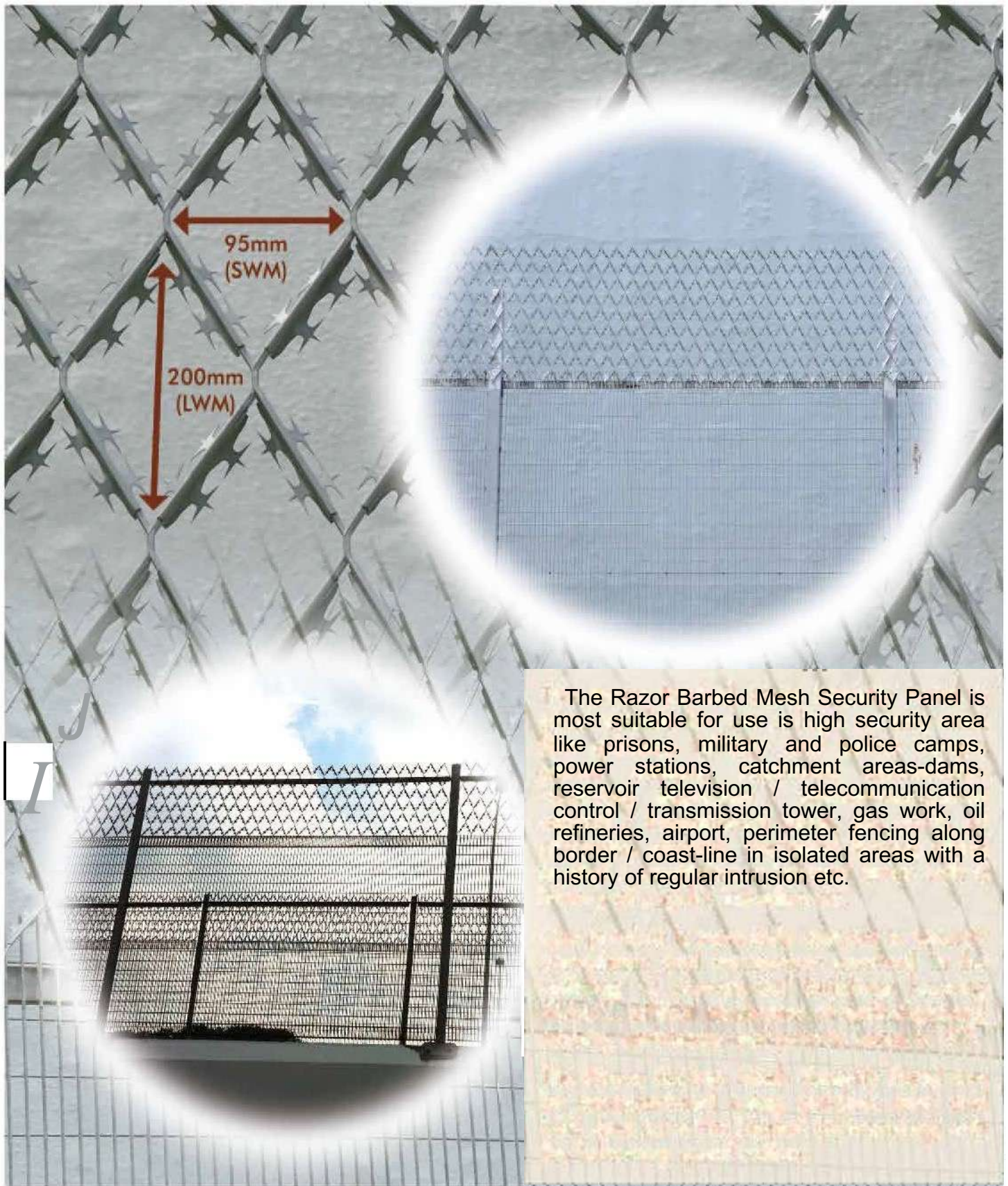

The Razor Barbed Mesh Security Panel is most suitable for use in high security areas like prisons, military and police camps, power stations, catchment areas-dams, reservoir television / telecommunication control / transmission tower, gas work, oil refineries, airport, perimeter fencing along border / coast-line in isolated areas with a history of regular intrusion etc.

TYPE	BLADE THICKNESS (mm)	MESH OPENING		Thickness (mm)	Strand Width (mm)	Standard Sheet Size SWM x LWM (mm)
		SWM (mm)	LWM (mm)			
HDG/ATM ZINC 500g/m <sup>2</sup>	0.6	95	200	3.0	3.5	±520 X ±2500



# ANTI-CLIMB EXPANDED METAL



Expanded metal anti-climb is developed for perimeter fencing along coastal line and military camps. The 12.5mm short way spacings do not allow gripping of hands or legs. The sharp razor edges will further deter intrusion.

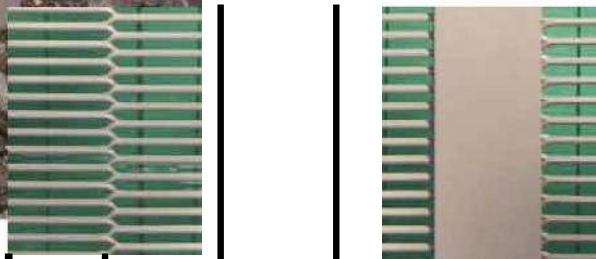

MATERIAL	MESH OPENING		Thickness (mm)	Strand Width (mm)	Standard Sheet Size SWM x LWM (mm)
	SWM (mm)	LWM (mm)			
HDG ZINC 500g/m <sup>2</sup>	12.5	75	3.0	3.0	2440 X 1220



# PVC Coated & Galvanized Chain-Link Fencing



## **PVC Coated Chain-Link Fencing Specifications:**

Wire Gauge	Standard Height	Standard Width
PVC Wire 8# (4.0mm)	3ft – 12ft	50ft
PVC Wire 9# (3.5mm)		
PVC Wire 10# (3.0mm)		
PVC Wire 12# (2.6mm)		

## **Galvanized Chain-Link Fencing Specifications:**

Wire Gauge	Standard Height	Standard Width
GI Wire 8# (4.0mm)	3ft – 12ft	50ft
GI Wire 9# (3.5mm)		
GI Wire 10# (2.7mm)		
GI Wire 12# (2.2mm)		

# Aluminium Slat



**\*Available in green and grey colour**  
**\*Single coil comes in 2" x 800m (Cut-to-Size available)**

## Razor Concertina Barbed Wire Coil (BT022 Razor)



Material	Loop Type	Loop Diameter	Length
SS304	Single	900mm	10m
SS316L-N12	Crossed	900mm	10m
Galvanized 50-70gm			12m - 15m
Hot-dipped Galvanized 280gm			10m
Galvanized 50-70gm	Crossed	600mm	10m

## Barbed Wire Coil



Material	Wire Diameter	Length/coil
Aluminum	2.5mm	50m / 100m
Galvanized (Zinc 50-70gm)	2.3mm	50m
Hot-dipped Galvanized (Zinc 250-260gm)	2.5mm	50m
SS316	2.1mm	50m
PVC Coated (Green)	2.3mm	75m



## GALFAN MATERIAL

Galfan is a type of steel that is coated with a zinc-aluminium layer instead of a traditional galvanized steel zinc layer because the zinc-aluminium layer has superior corrosion resistance.

This superior corrosion resistance allows thinner layers of protective coatings to be applied.

The eutectic composition of 95% Zn and 5% Al improves the coating adhesion and enables a lamellar coating structure in micro-scale, which makes it a ductile and well-suited coating for deep drawing.

A thin layer of zinc-aluminium improves the weldability of the material because the reduced protective layer thickness allows for greater weld penetration and less dilution of zinc into the weld pool.

Galfan coating is produced both-sided in a continuous hot-dip coating process. Because of the sacrificial nature of the Galfan coating, it provides corrosion protection for areas of exposed steel surfaces, such as cutting edges and possible areas where coating has damaged (scratches, impacts, etc.).

Full corrosion protection is also achieved in areas that have been heavily formed because the peeling tendency of low-friction and tightly bonded coating is low.

